

L'OISEAU BLEU

Variation féminine

Extrait de la "Belle au Bois Dormant"

Musique de Piotr Ilitch Tchaïkovski

Chorégraphie : Marius Petipa, remontée par G. Canova

Cinétographie Laban : Ch. Eiffes - Jacqueline Challet-Haas
(1972-1983)

Graphie : Yvette Alagna 
sur GRAPHICWORKS 2.0

Introduction

2
4

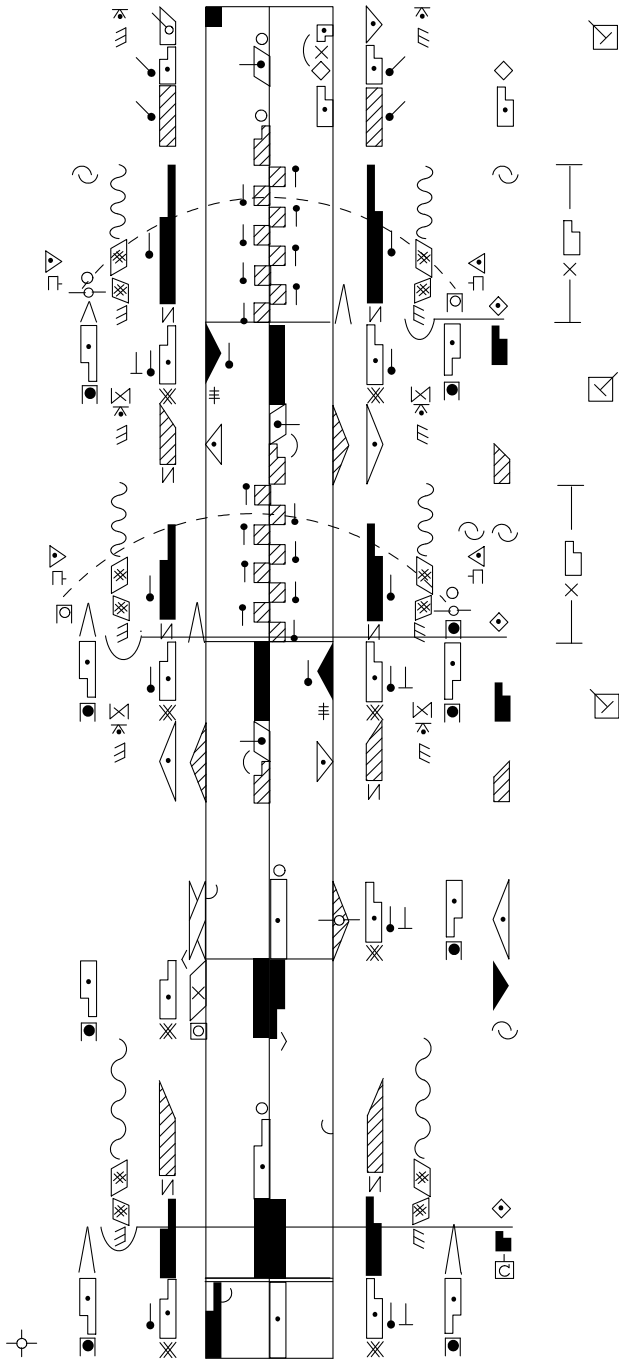
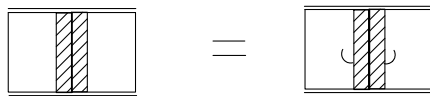
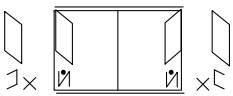

6

5

4

3

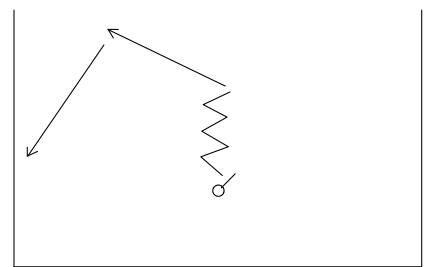
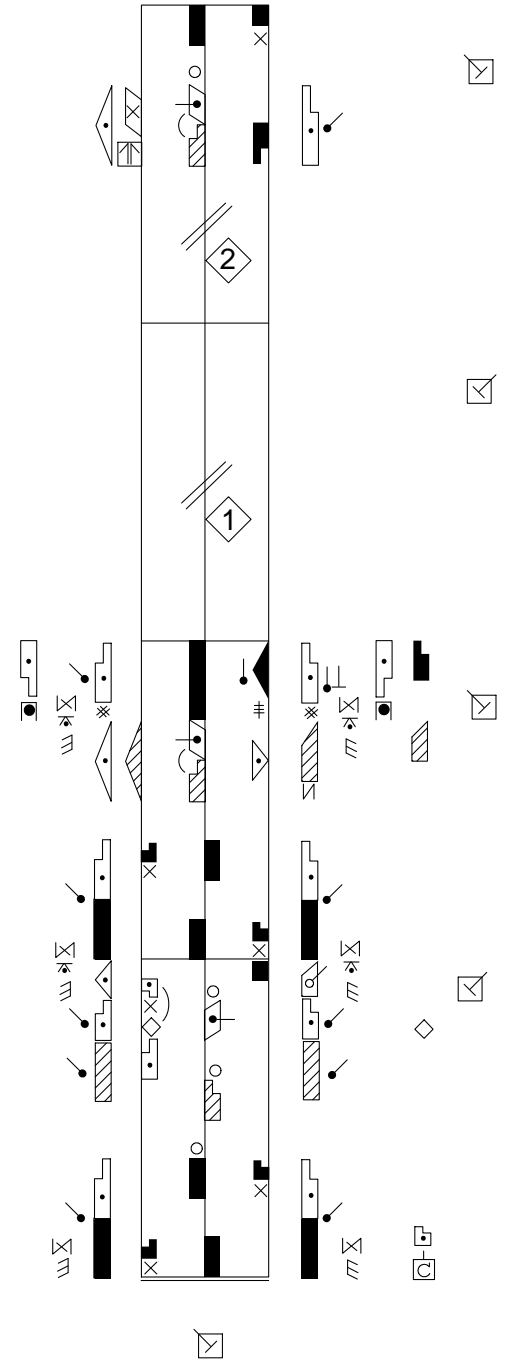

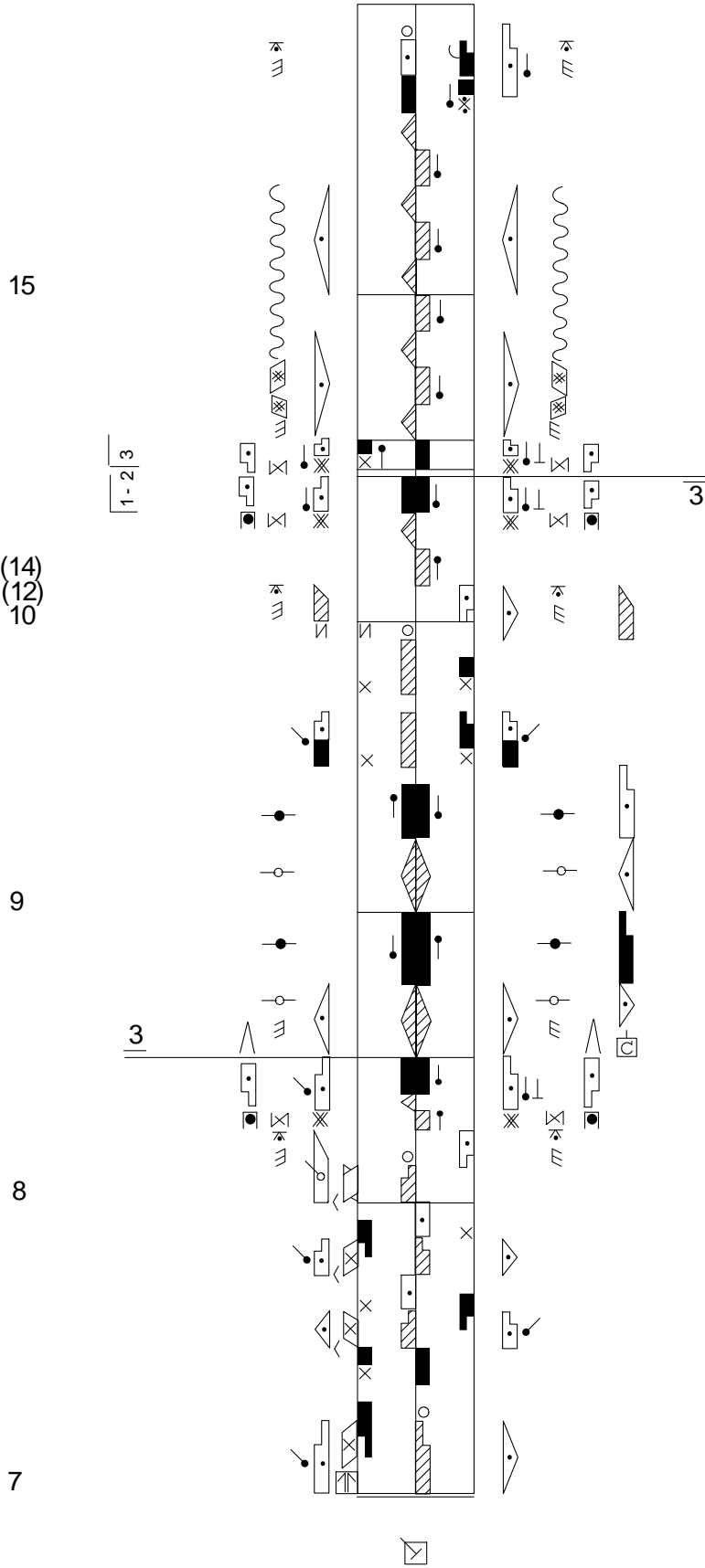

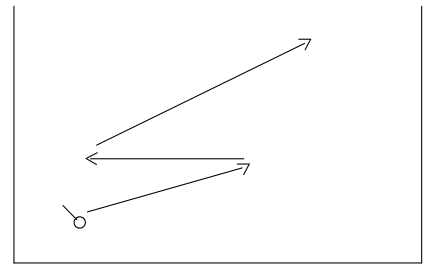
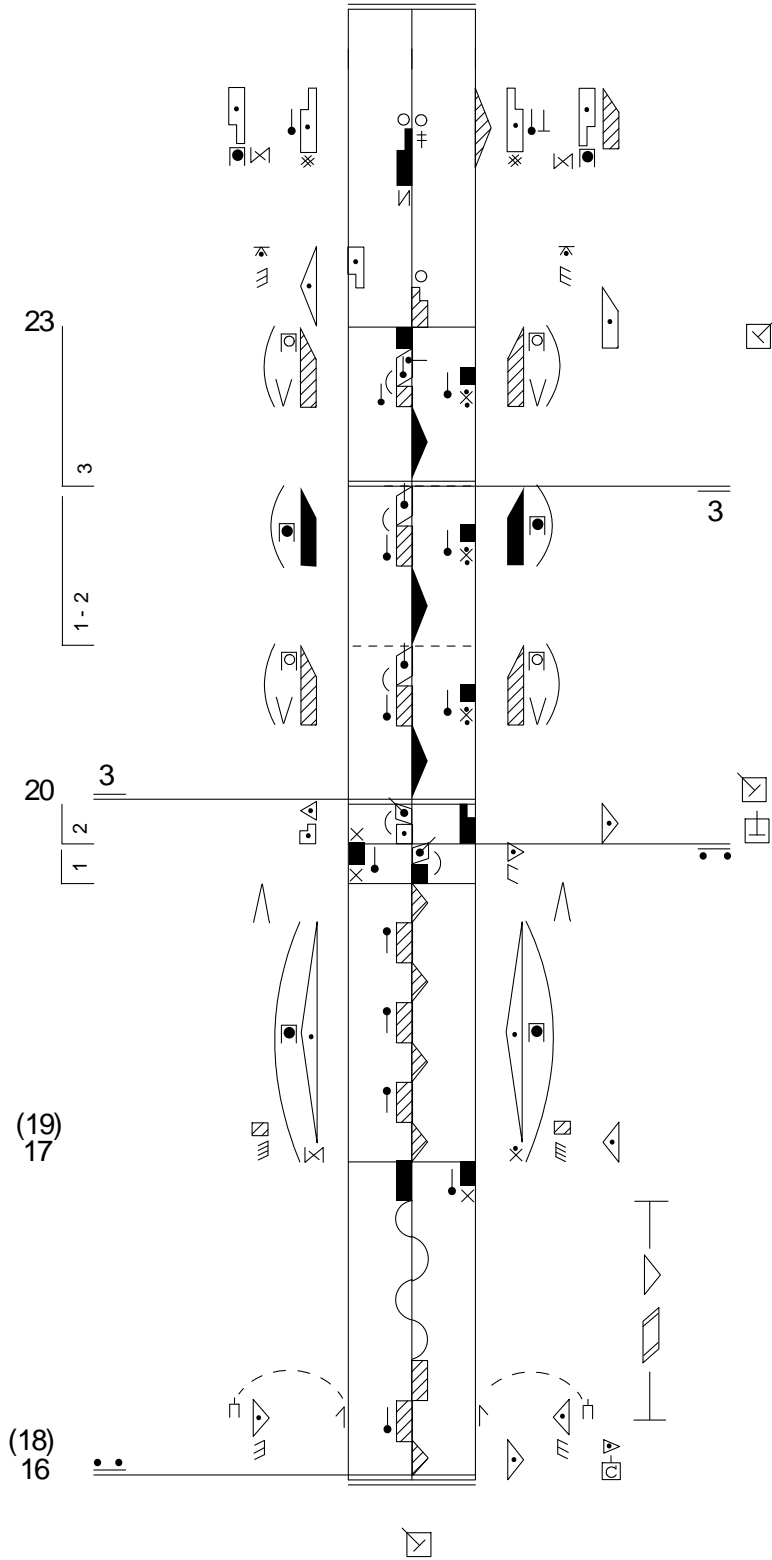

16-23